

# Submittal Sheet



## S-line Inline Centrifugal Fans

### S-line Dimensional Data

Fan Model	A	B	C	D	E	F	G	H	I	J	K	L	Ship Wt
S-600	5.91	15.37	9.02	1.26	3.25	8.33	12.81	11.18	0.20	4.20	3.73	3.94	10.6
S-800	7.95	16.64	10.38	1.22	3.69	9.41	14.19	12.17	0.20	4.97	4.48	4.57	14.8
S-1000	9.843	17.394	13.297	1.181	4.941	11.489	14.993	12.582	0.197	6.014	5.503	5.709	19.8

All dimensions in inches

Weights in pounds

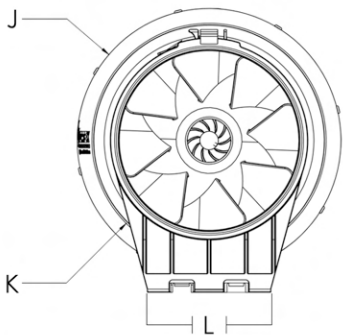
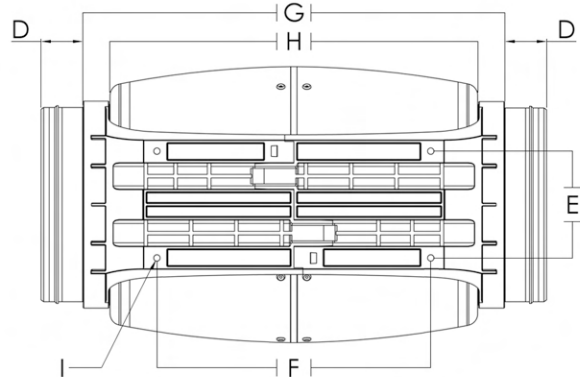
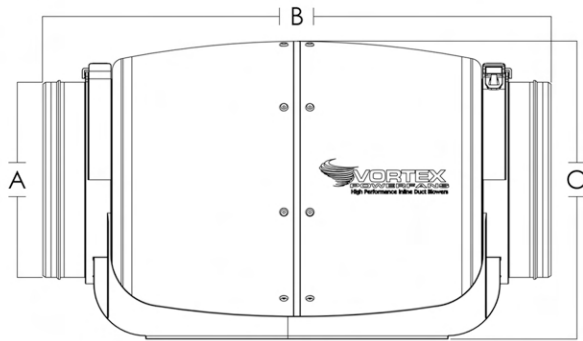

### Standard Features

- Double insulated wall to prevent condensation and reduce noise level
- Integrated backdraft damper to prevent air leakage when the extractor is not operating
- High impact resistant polycarbonate casing for heavy duty applications
- The motor is 100% speed controllable, highly efficient, low power consumption, built with permanently lubricated ball bearings and thermal overload protection with automatic reset
- Mixed flow impeller design for quiet operation and high air flow
- 10 year manufacturers warranty
- ETL Listed
- AMCA Air Listed

### S-line Performance Data

FAN MODEL	Duct Dia.	RPM	Volts	Rated Watts	Max Amps	Static Pressure in Inches W.G.										Max Ps
						0"	.125"	.2"	.25"	.375"	.5"	.75"	1.0"	1.25"	1.5"	
S-600	6"	2720	120	72	0,68	340	323	312	305	285	265	215	39	---	---	1.185
S-800	8"	3150	120	232	1,99	711	697	688	682	666	649	612	570	501	204	1.844
S-1000	10"	2970	120	232	2,12	1082	1051	1032	1019	984	946	866	781	687	197	1.766

Performance certified is for installation type D - Ducted inlet, Ducted outlet. Speed (RPM) shown is nominal. Performance is based on actual speed of test. Performance ratings include the effects of appurtenances (accessories) Inlet Duct, Inlet Bell, Outlet Duct

### S-line Fan Specifications

Fan Tag	Fan Model	Qty	CFM	SP	Accessories	Remarks

Project \_\_\_\_\_ Submitted \_\_\_\_\_  
 Customer \_\_\_\_\_ Approved \_\_\_\_\_  
 Location \_\_\_\_\_



2480 Boul. des Entreprises Terrebonne, Quebec J6X 4J8 CANADA  
 T: 450.477.1100 F: 514.313.5700 TF: 1.800.489.1301  
 WWW.ATMOSPHERE.COM

FEBRUARY 2020

Customer support : info@atmosphere.com  
 Sales inquiries : sales@atmosphere.com



## Panasonic

Panasonic is the exclusive distributor of Atmosphere products in the US

Panasonic IAQ Division For Order Information  
 Two Riverfront Plaza PHONE: 866-292-7299  
 Newark, NJ 07102 FAX: 888-553-0723  
 na.panasonic.com/us/iaq ventfans@us.panasonic.com

Design and specifications subject to change without notice.

\*Pending AMCA Certification\*