

Specification Submittal Data / Panasonic ERV

Description

Ceiling or wall mount Energy Recovery Ventilator (ERV) provides a tempered air supply, humidity control, and a balanced amount of exhaust to help maintain balanced, positive or negative pressure throughout the home. Built-in ASHRAE 62.2 Timing function helps ensure code compliance.

Motor/Blower:

- ERV shall have Hi/Lo Speed Occupant Controlled Boost Capability
- Two (2) enclosed DC brushless motors rated for continuous run.
- ERV Supply and Exhaust ventilation rates shall be manually adjustable for 50-60-70-80-90-100 CFM.
- Power rating shall be 120 volts and 60 Hz.
- Motor equipped with thermal cut-off fuse control.
- Removable, permanently lubricated, plug-in motor.
- Power shall be supplied by hard wired method.

Housing:

- 22 gauge galvanized steel body.
- Four 4" or 6" intake and exhaust ducts.
- Built in damper on Outdoor Air (OA) closes during defrost function when the outdoor temperature is too cold.
- Filters on supply and exhaust air extend the life of the ERV core.
- (4) Pressure ports allow for easy airflow verification.
- Pre-drilled mounting bracket can accommodate 16", 19", or 24" on center.

Maintenance:

- MERV 8 filter included; MERV 8 (FV-FL0810VE1) and optional MERV 13 (FV-FL1310VE1) replacements available.
- Unobtrusive alarm notifies owner for filter check and maintenance.

Warranty:

- DC Motors: 6 years from original purchase date
- All Parts: 3 Years from original purchase date.

Architectural Specifications:

ERV shall be ceiling or wall mount type with built-in speed selectors for both Supply and Exhaust air. Select from 50/60/70/80/90/100 CFM. ERV shall have 100 Net CFM on the exhaust ports and 100 Net CFM on the supply ports as tested in accordance with HVI 915 and 916 standards at 0.1 static pressure in inches water gauge. ERV shall have 100 Net CFM on the exhaust ports and Net 100 CFM on the supply ports at 0.4" w.g. static pressure. ERV shall have Hi/Lo Speed Occupant Controlled Boost Capability. Power consumption shall be no greater than 81 watts at 0.1" w.g. and 100 watts at 0.4" w.g. static pressure. Apparent Sensible Effectiveness for heating shall be no less than 83% at 53 CFM net air flow at 32°F (0°C) as tested in accordance with CSA-C439. Total Recovery Efficiency for cooling shall be no less than 60% at 49 CFM net air flow at 95°F (35°C). The outdoor air damper shall close when outdoor temperatures are < 14°F (-10°C) to prevent freezing of the core. The (2) motors shall be totally enclosed DC brushless motors rated for continuous run. DC motor speed shall automatically increase when the fan senses static pressure to maintain selected CFM. ERV shall incorporate an ASHRAE 62.2 Intermittent Timing function for code compliance. ERV shall have standby/low speed to high speed control airflow capability as desired by occupant. Power rating shall be 120v/60Hz. Power shall be supplied by hard wired method. Duct diameters shall be no less than 4". ERV can be used to comply with ASHRAE 62.2, LEED, IAP, California Title-24, and WA Energy Code

ERV Core Technology:

- Indoor and outdoor air passes through Panasonic's capillary core technology. This process tempers supply air while transferring moisture and energy.
- Built in Frost Prevention Mode prevents the core from freezing. Frost Prevention Mode is intuitive and operates without homeowner intervention.
- Core material permeated with anti-mold treatment.

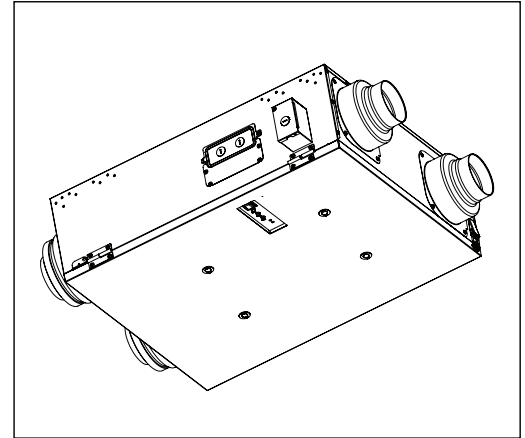

FV-10VE2H

Optional Exterior Wall Cap (see next page)

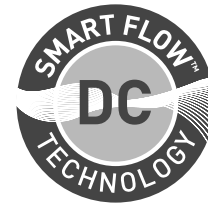

DC Motor Technology

When the ERV senses static pressure, its speed is automatically increased to ensure that the desired CFM is not compromised.

For complete Installation Instructions visit na.panasonic.com/us/iaq

Model	Quantity	Comments	Project:
			Location:
			Architect:
			Engineer:
			Contractor:
			Submitted by:
			Date:

Panasonic
IAQ Division
Two Riverfront Plaza
Newark, NJ 07102
na.panasonic.com/us/iaq



Specification Submittal Data / Panasonic ERV (Continued)

Specifications: Intelli-Balance 100 FV-10VE2H		
Static Pressure in inches w. g.	0.1	0.4
Net Exhaust Air Volume (CFM)	100	100
Net Supply Air Volume (CFM)	100	100
Power Consumption (watts)	81	90
Power Rating (V/Hz)	120/60	
ENERGY STAR [®] Certified	Yes	

Energy Performance: Intelli-Balance 100 FV-10VE2H							
Supply Temperature		Net Air Flow		Power Consumed (Watts)	Sensible Recovery Efficiency	Apparent Sensible Effectiveness	Net Moisture Transfer
°C	°F	L/S	CFM				
Heating							
0	32	25	53	29	80	83	78
0	32	31	66	39	77	81	74
0	32	40	85	68	73	77	71
Cooling				Total Recovery Efficiency			
35	95	23	49	32	60		

Optional Accessories

WhisperVent[™] Wall Cap

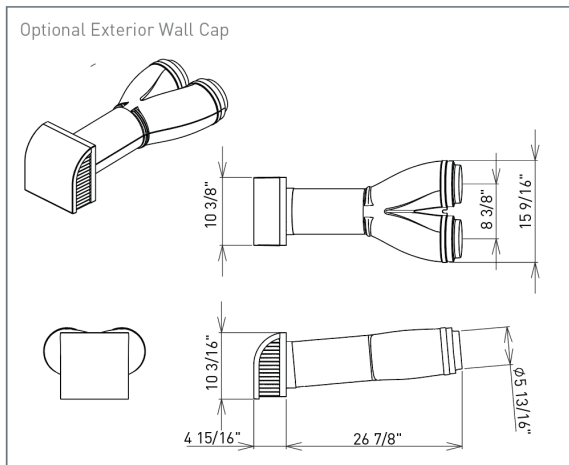

Exterior Wall Cap

FV-WC10VE1 polypropylene wall cap with polystyrene adaptor allows both exhaust (from the right) and supply (from the left) airflow through a 7.5" hole in the building envelope. The dividers inside the bottom portion of the Y shape chamber and the new wall cap help prevent cross contamination.

Performance Curve 4" or 6" duct

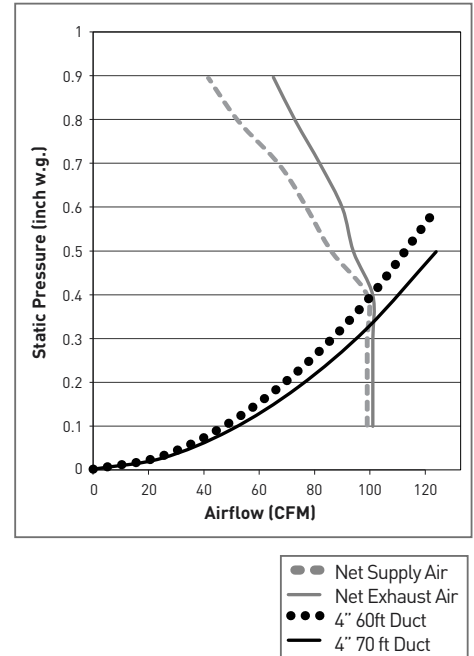

Panasonic
IAQ Division
Two Riverfront Plaza
Newark, NJ 07102
na.panasonic.com/us/iaq

